



II. Hand-on Session: Comparative Flux Study

**Amnat Chidthaisong,
JGSEE, May 3, 2007**



We will compare:

- Two detection techniques:
 - Online, semiconductor-based sensor
 - Gas Chromatography

Method for Emission Measurements



3 May 2007, Bangkok

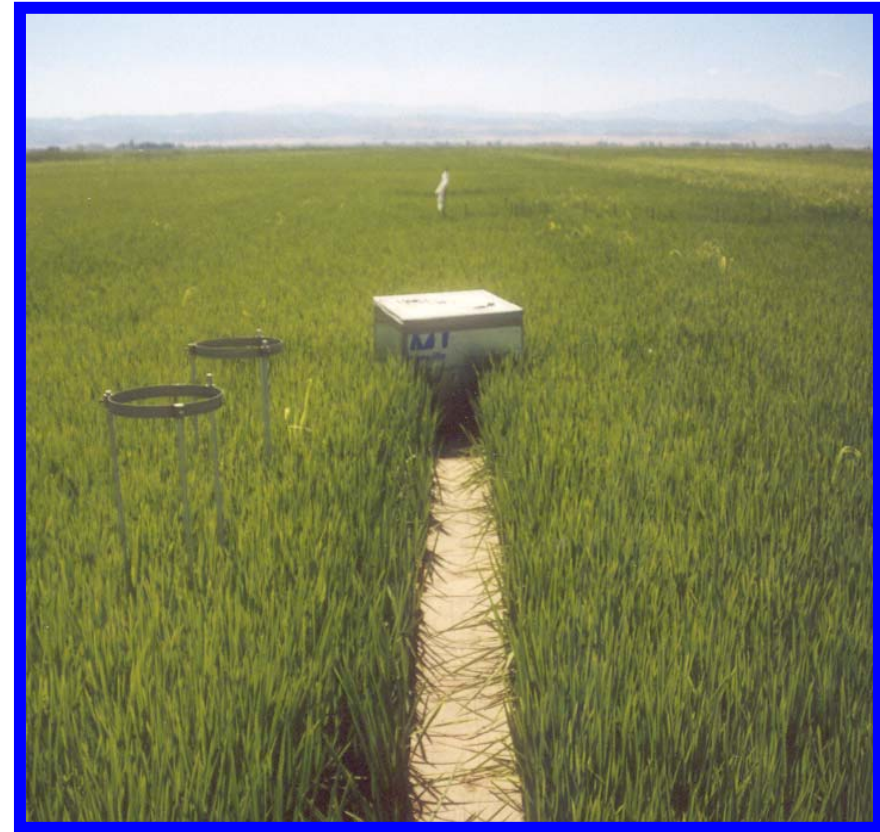

APN Workshop

Current Procedures

**Chamber
enclosure**

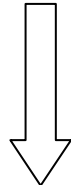

Gas samples

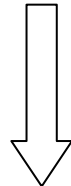

Gas Chromatography

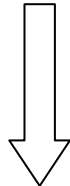

Flux estimate

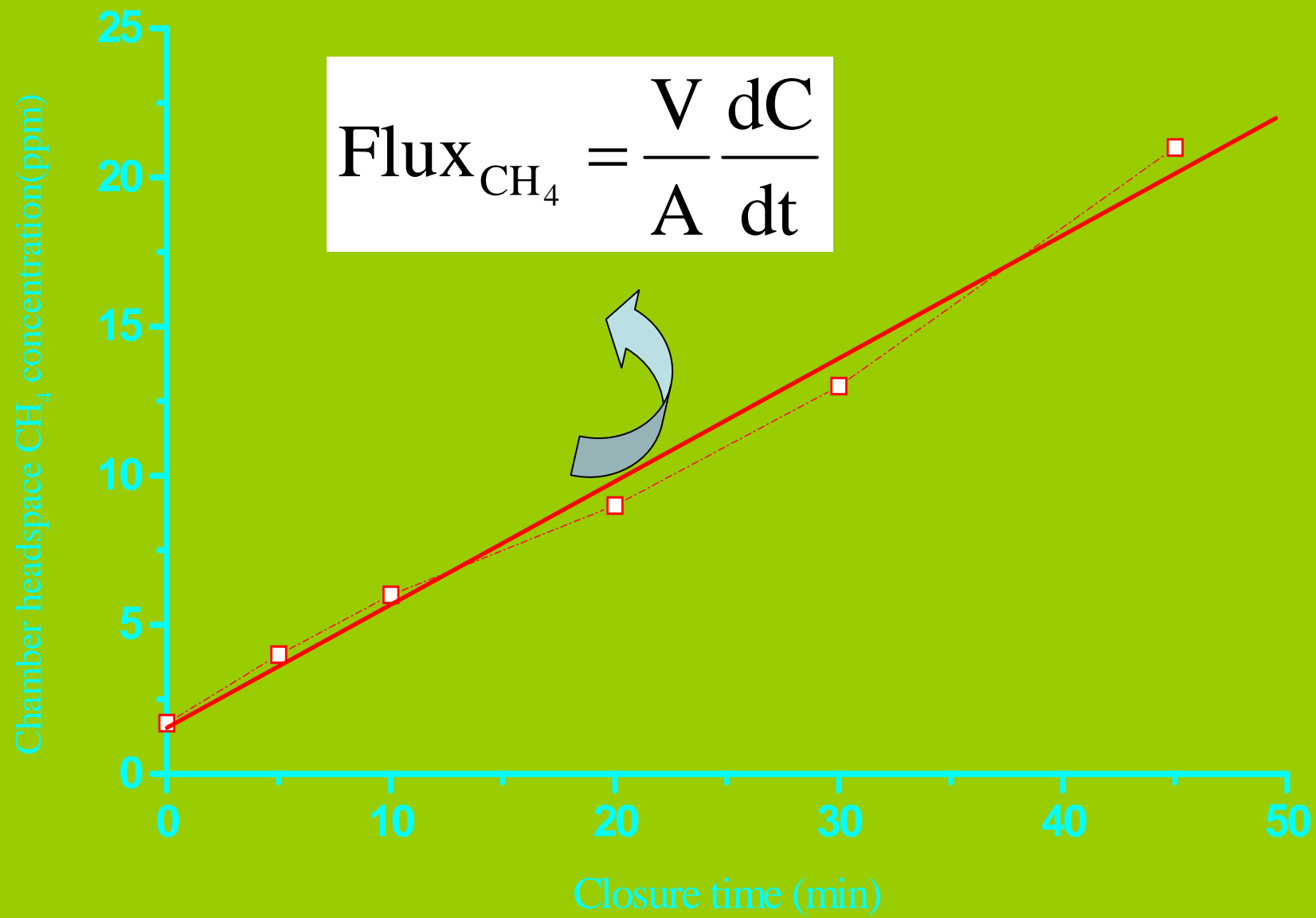

$$\text{Flux}_{\text{CH}_4} = \frac{V}{A} \frac{dC}{dt}$$



Drawbacks

- Time consuming
- Limited replication
- Expensive
- Accuracy concerns
- Not applicable in the remote area

Chamber enclosure

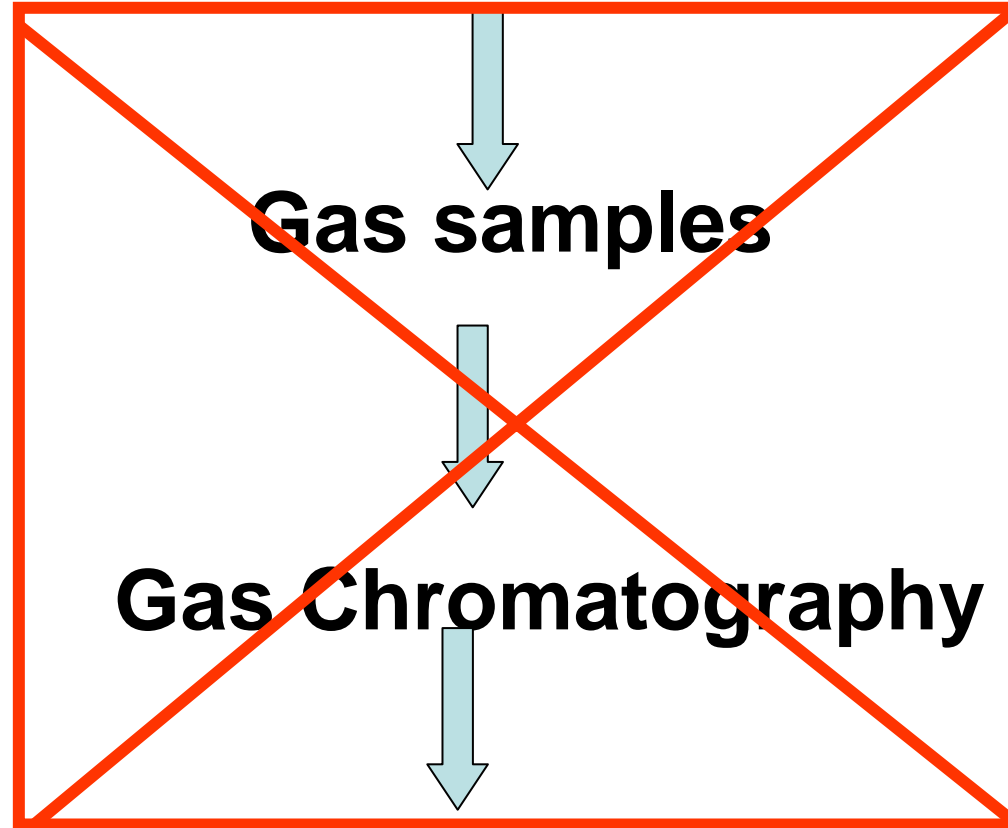

Gas Chromatography

Flux estimate

Sensing Mechanism

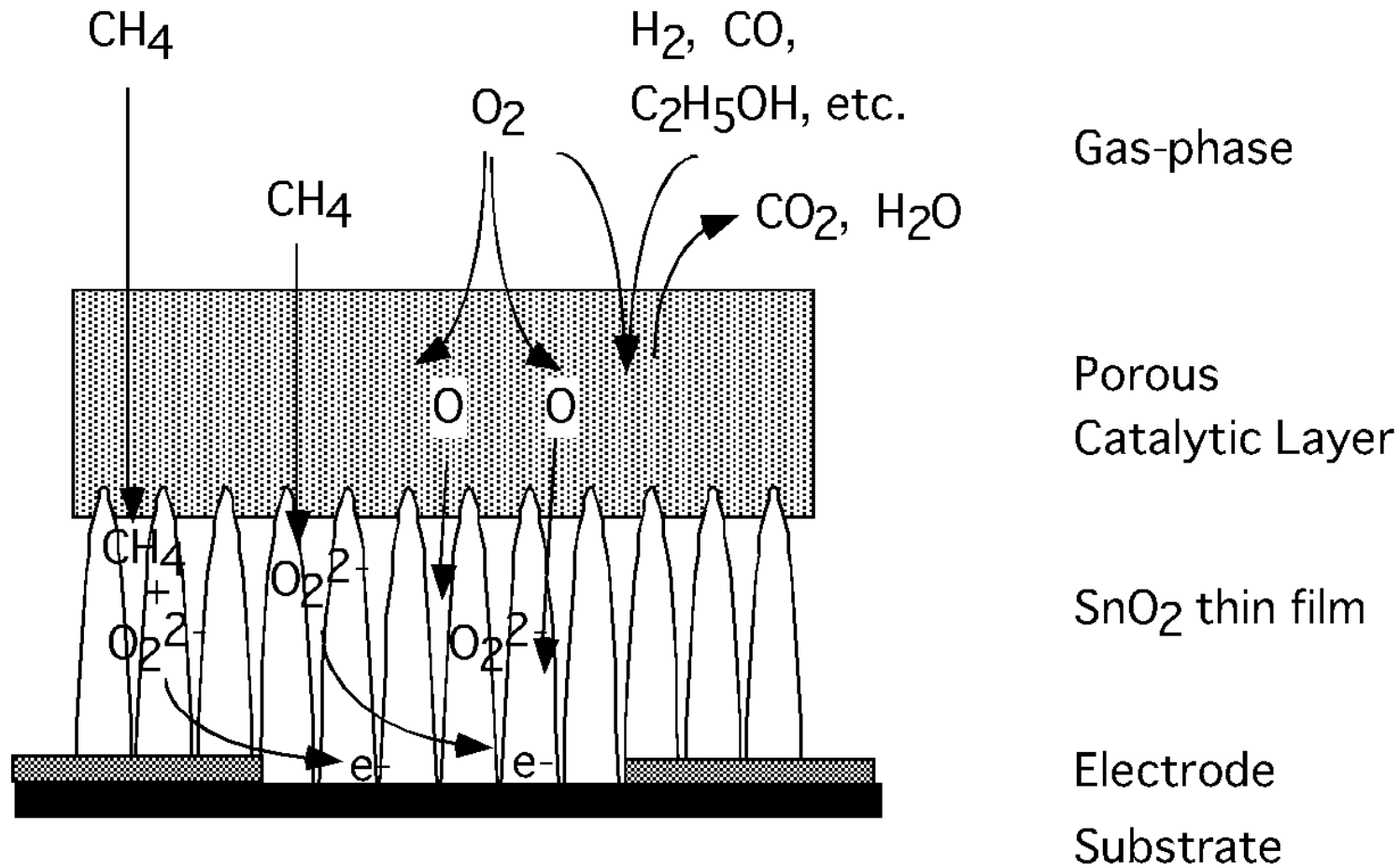

Conductivity is proportional to the amount of reduced gas
 $\text{R} + \text{O}_2^{2-} \rightarrow \text{RO} + 2e^-$ ions are released;

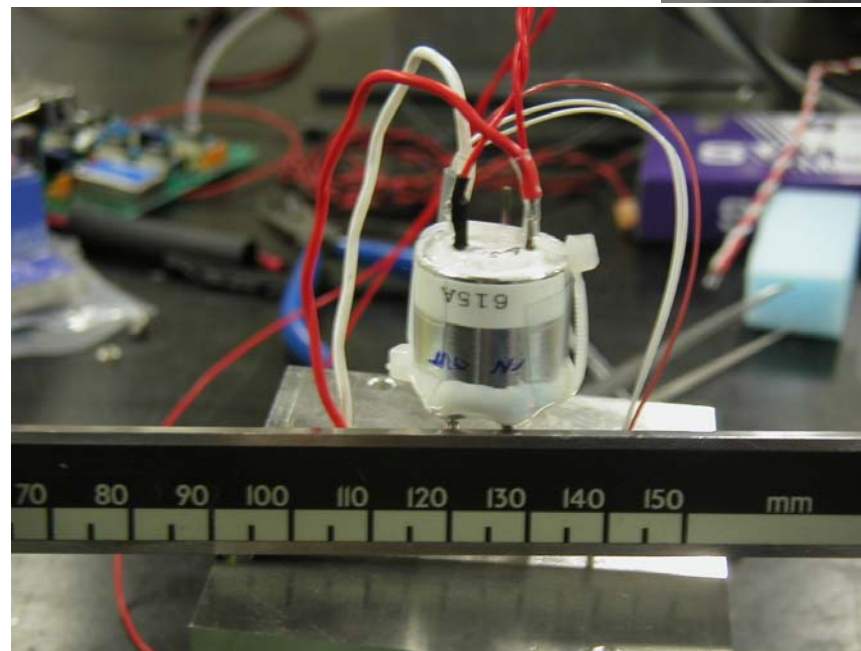

3 May 2007, Bangkok

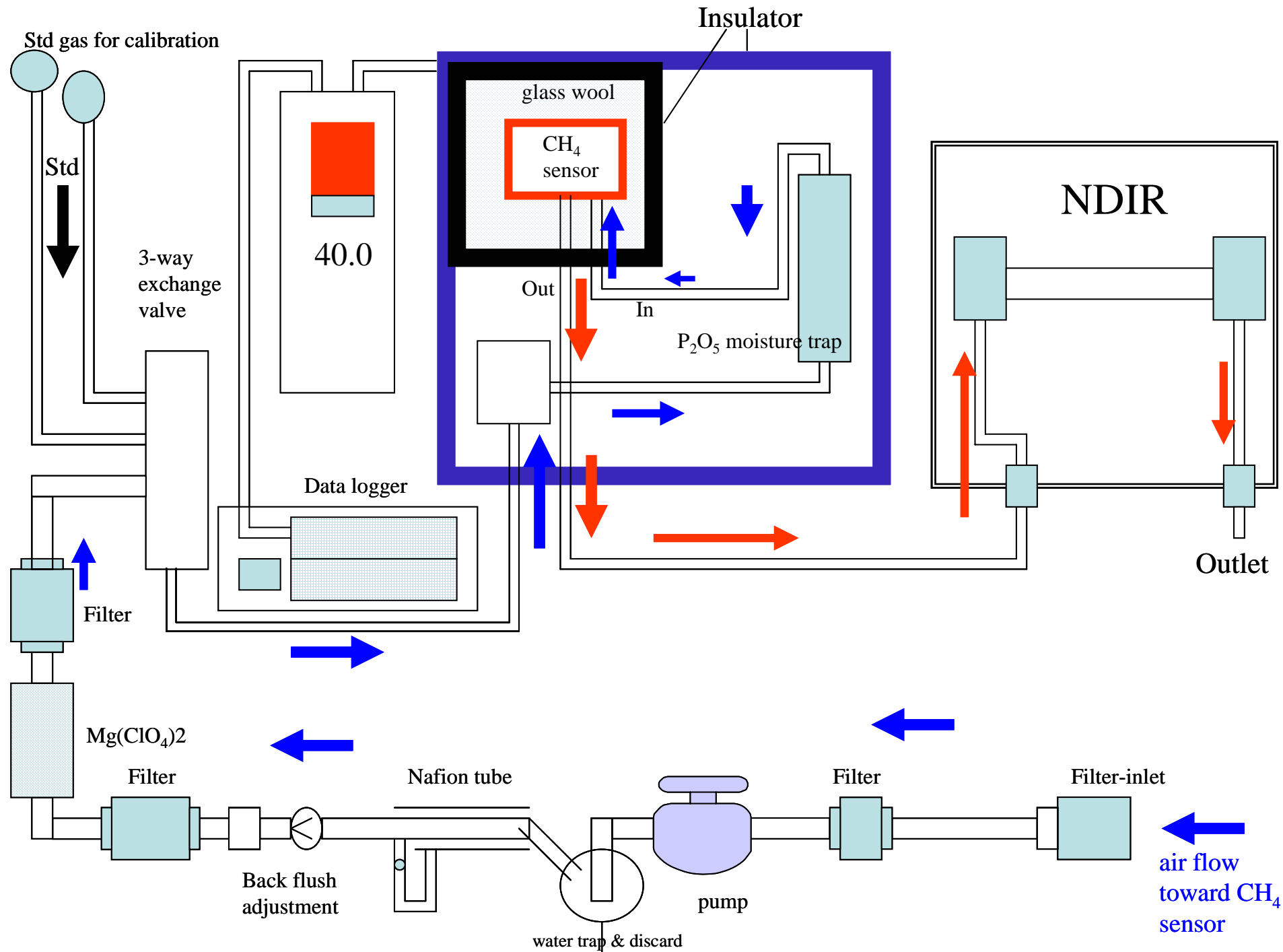



CH₄ Determination

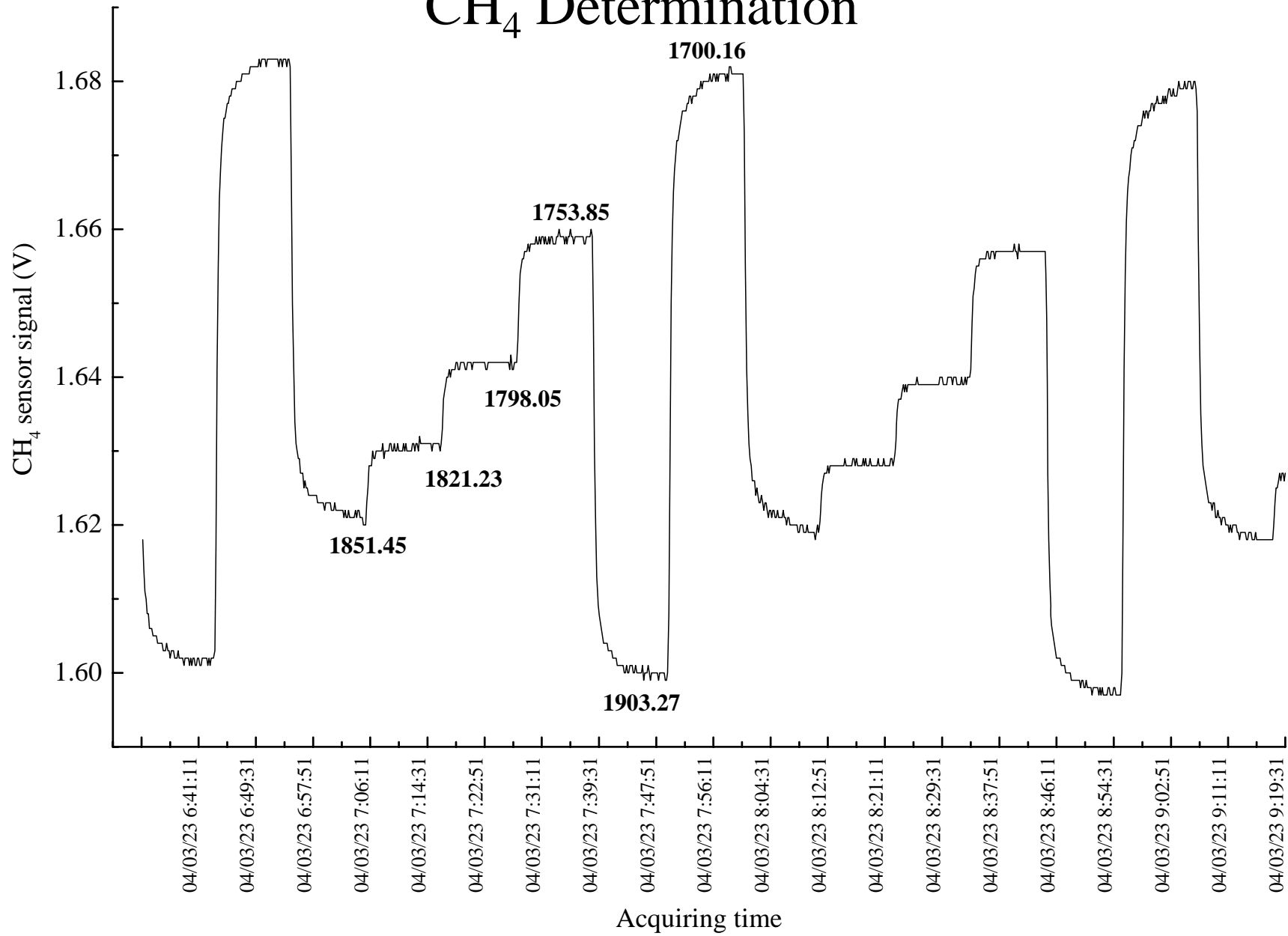

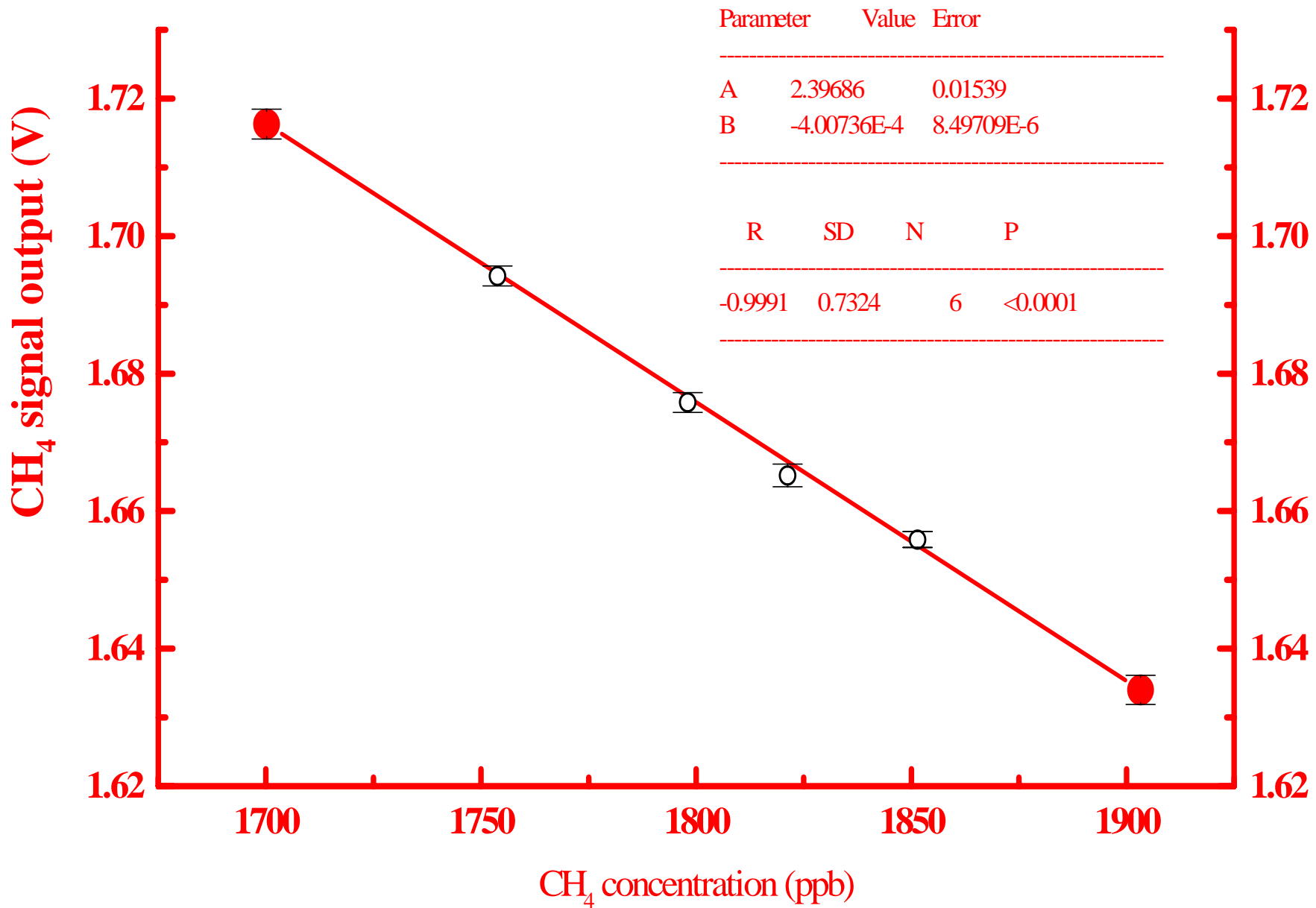

Measurement Range

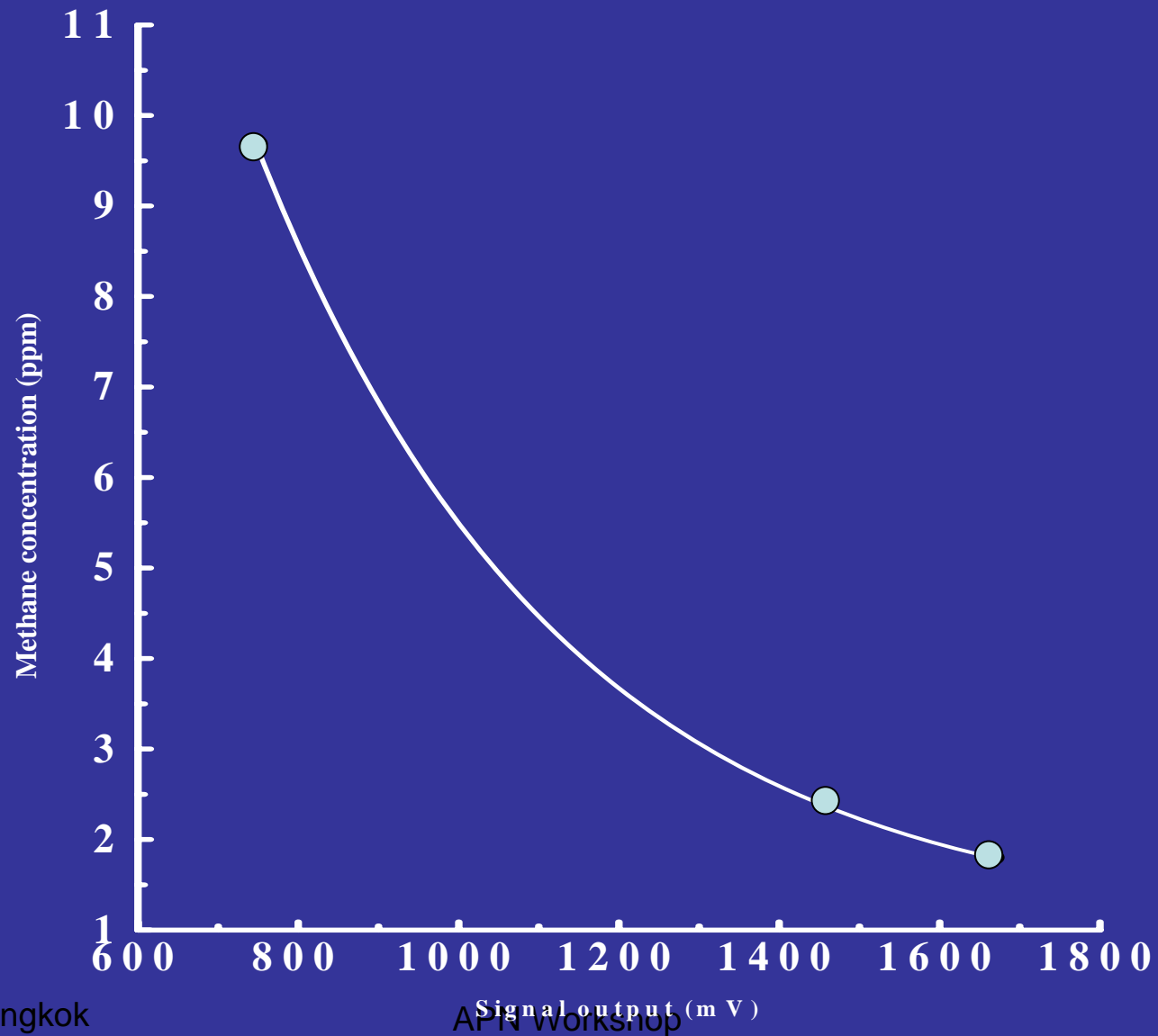

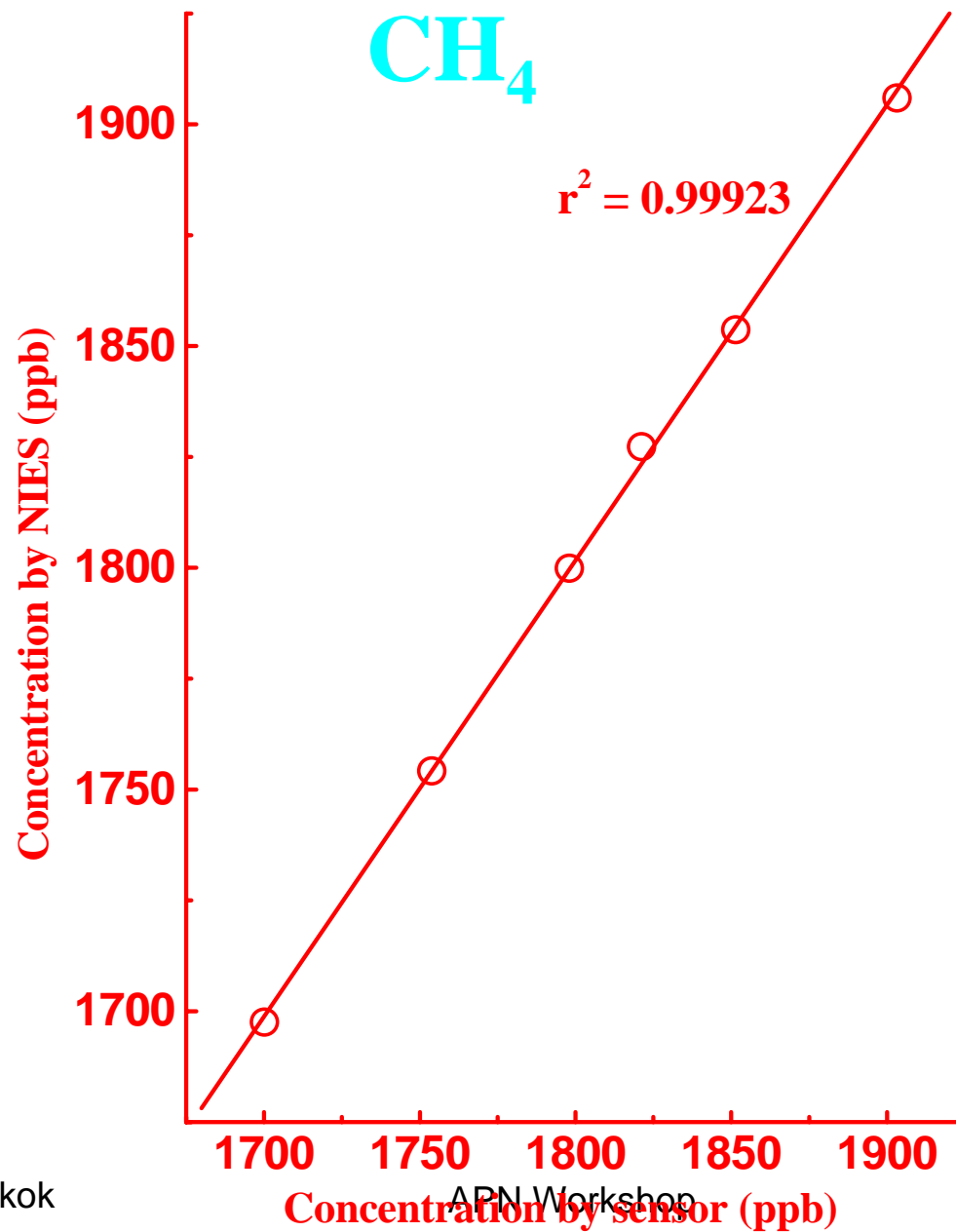

CO₂ Determination

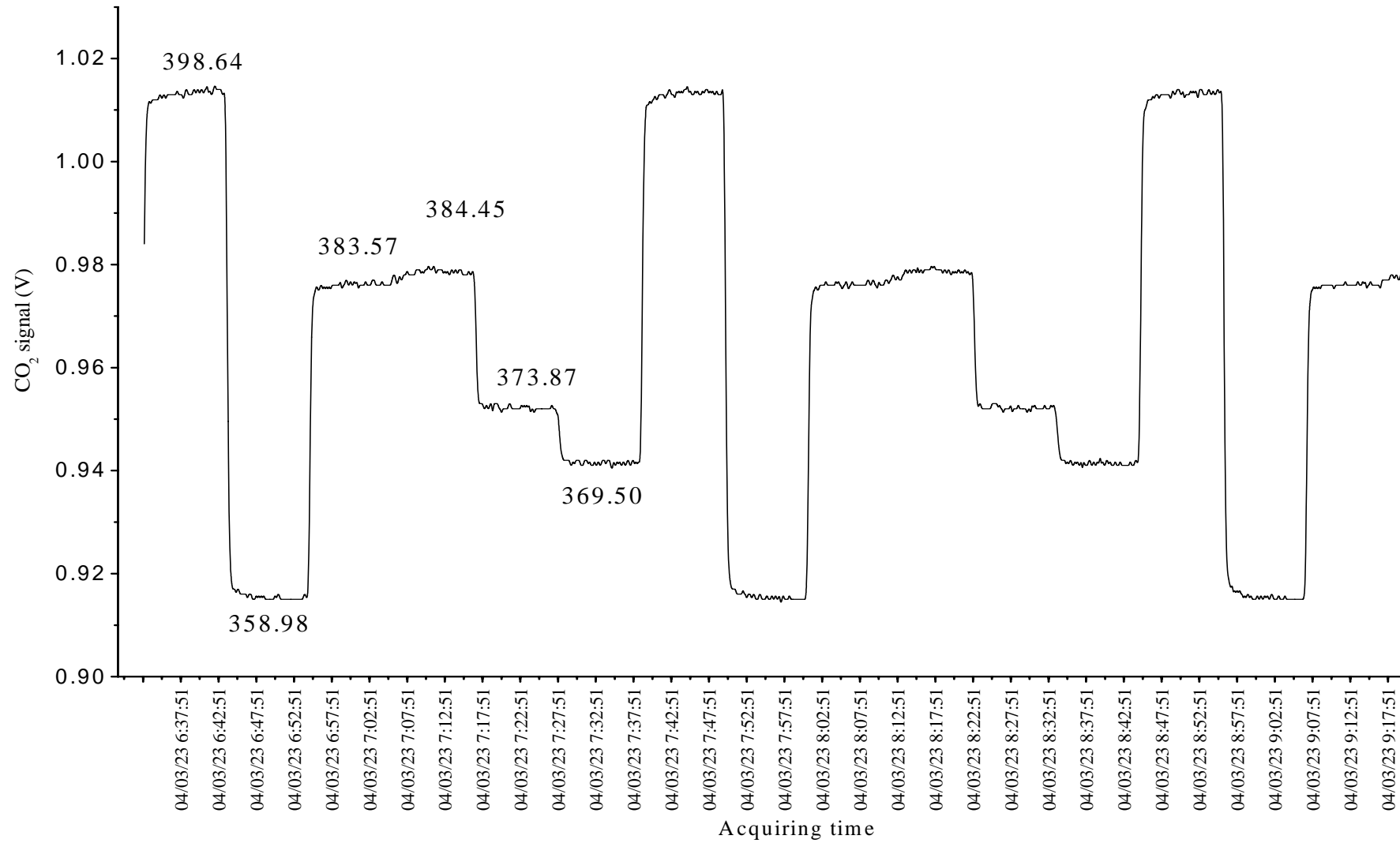

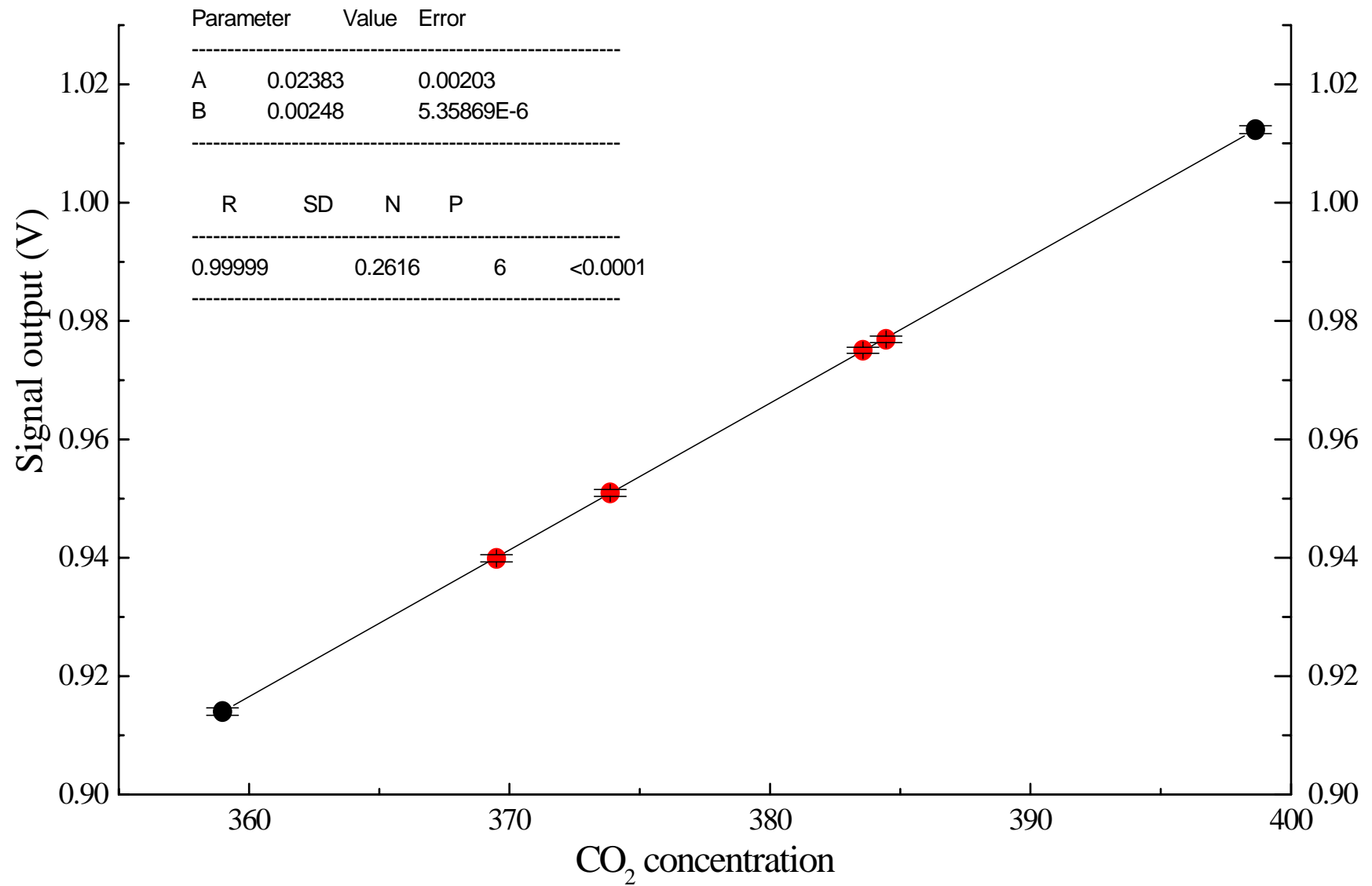

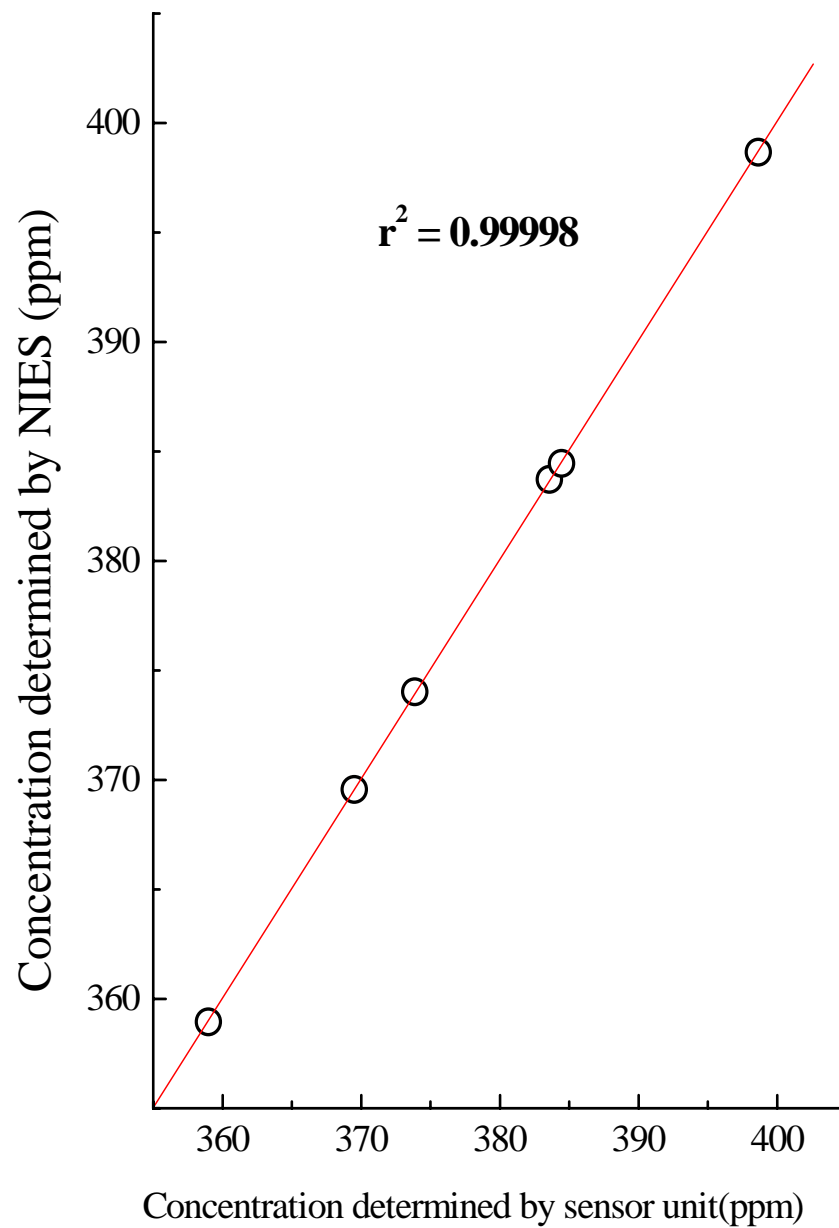
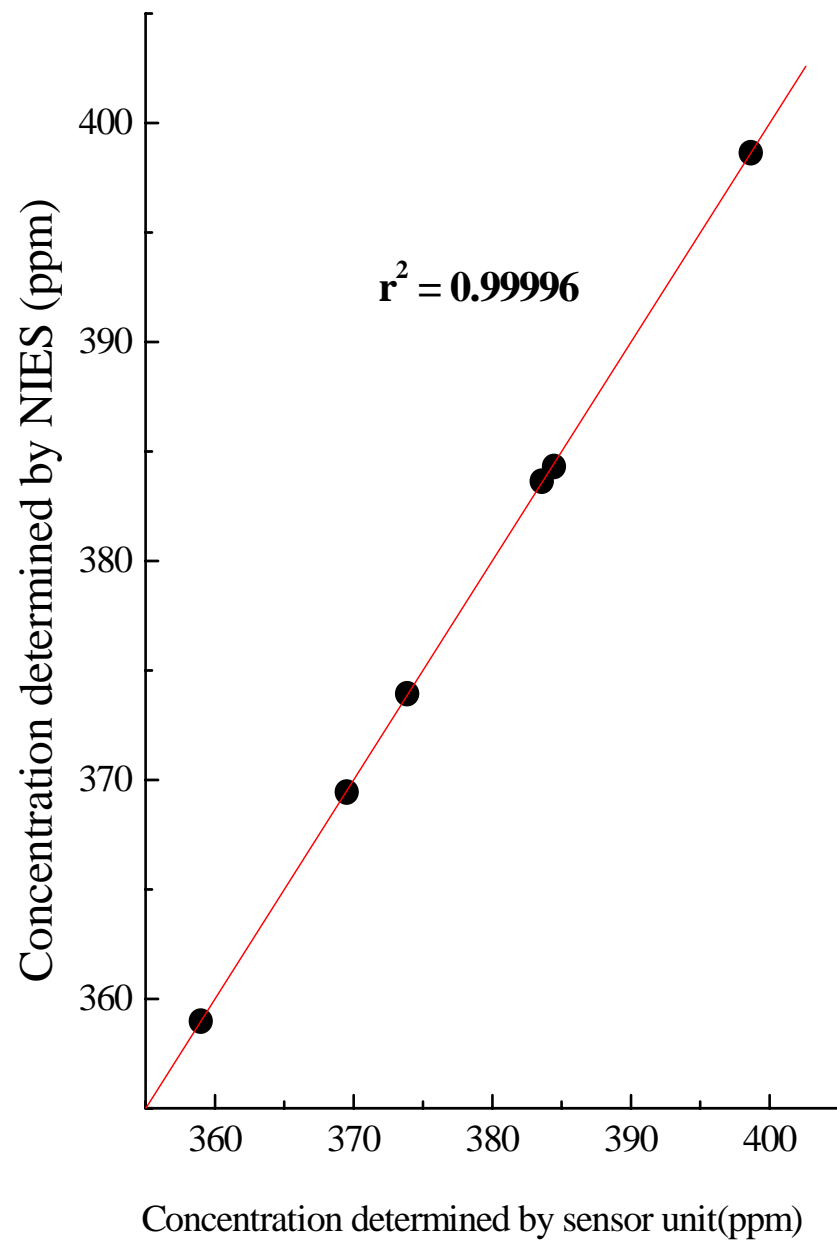





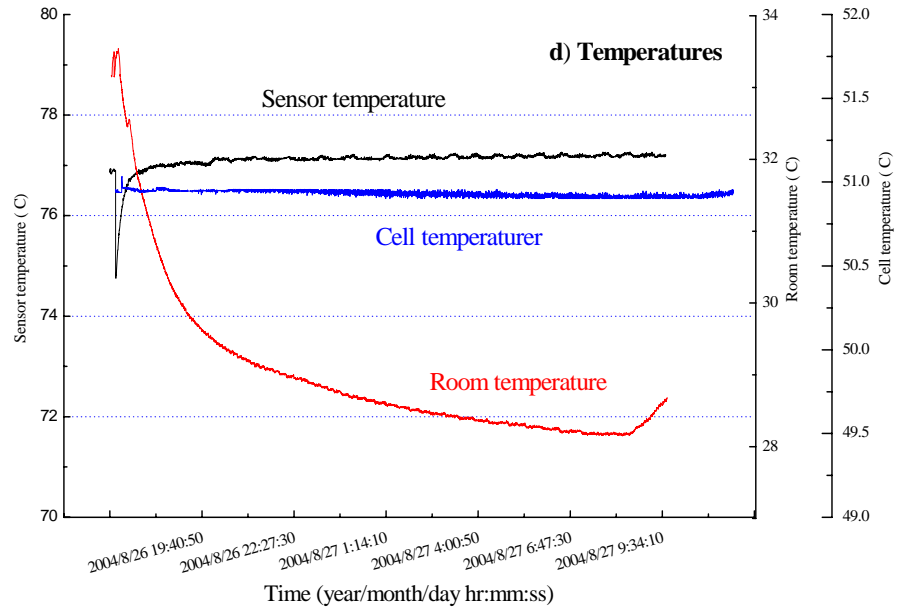
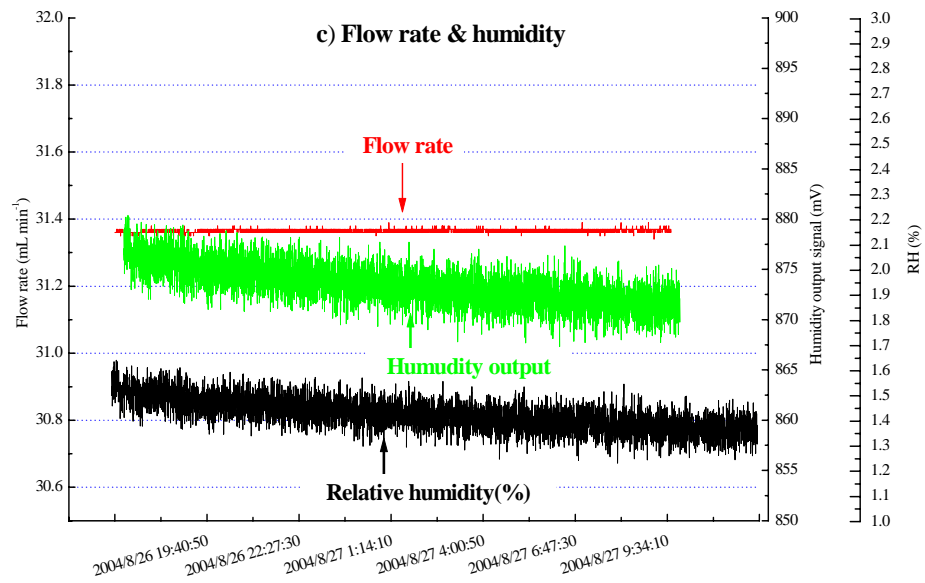
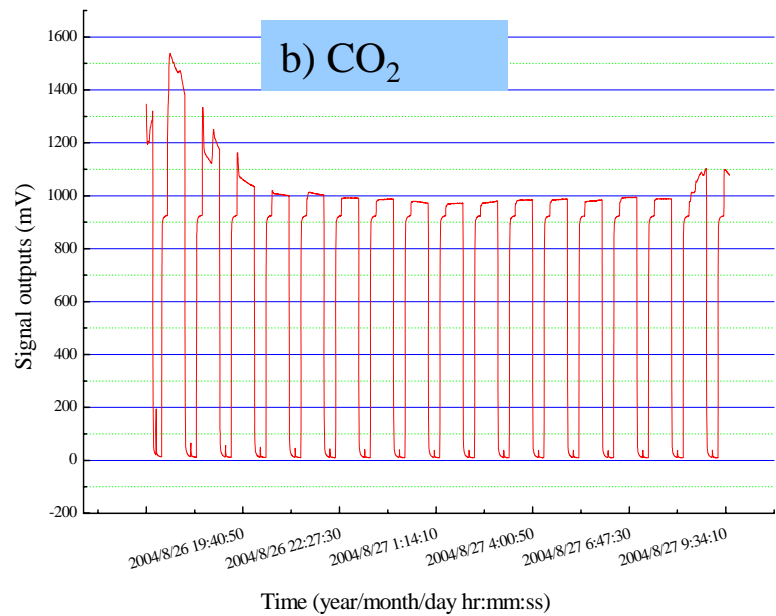
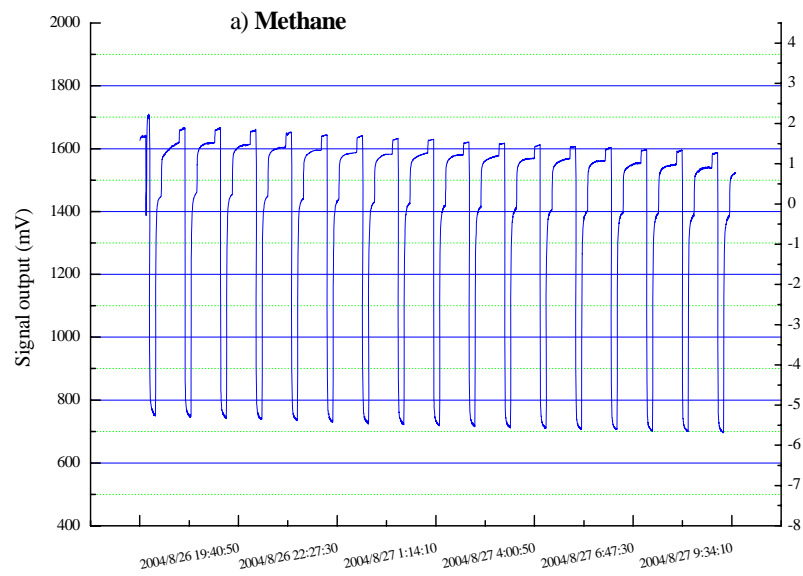

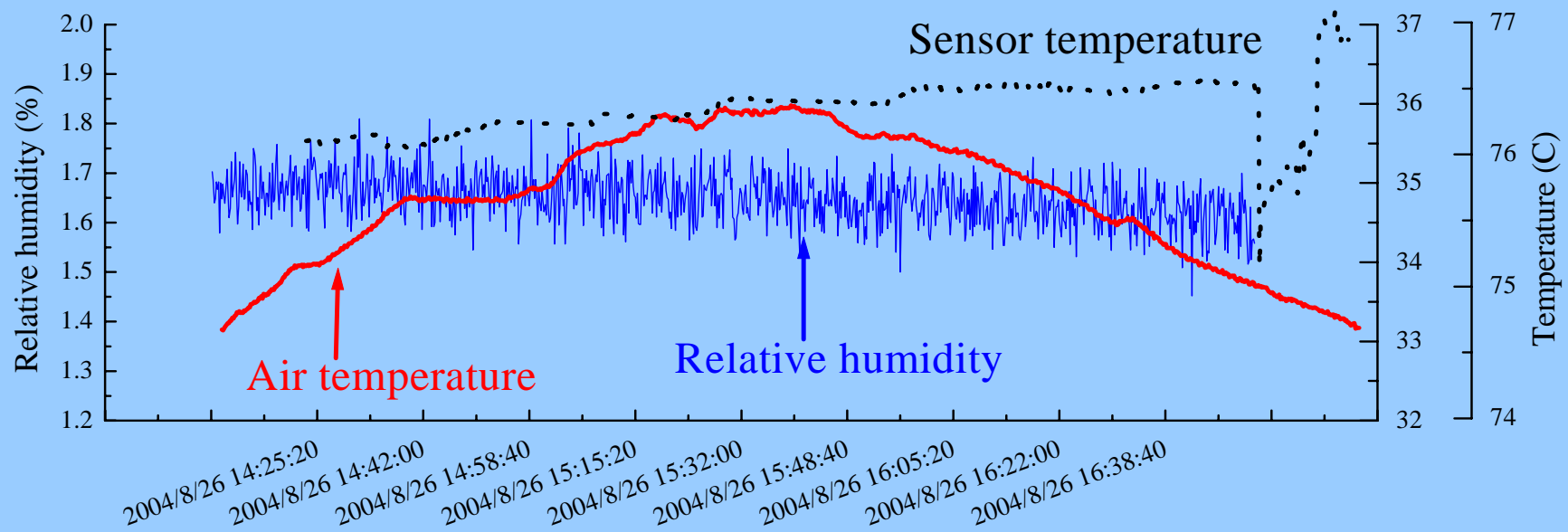
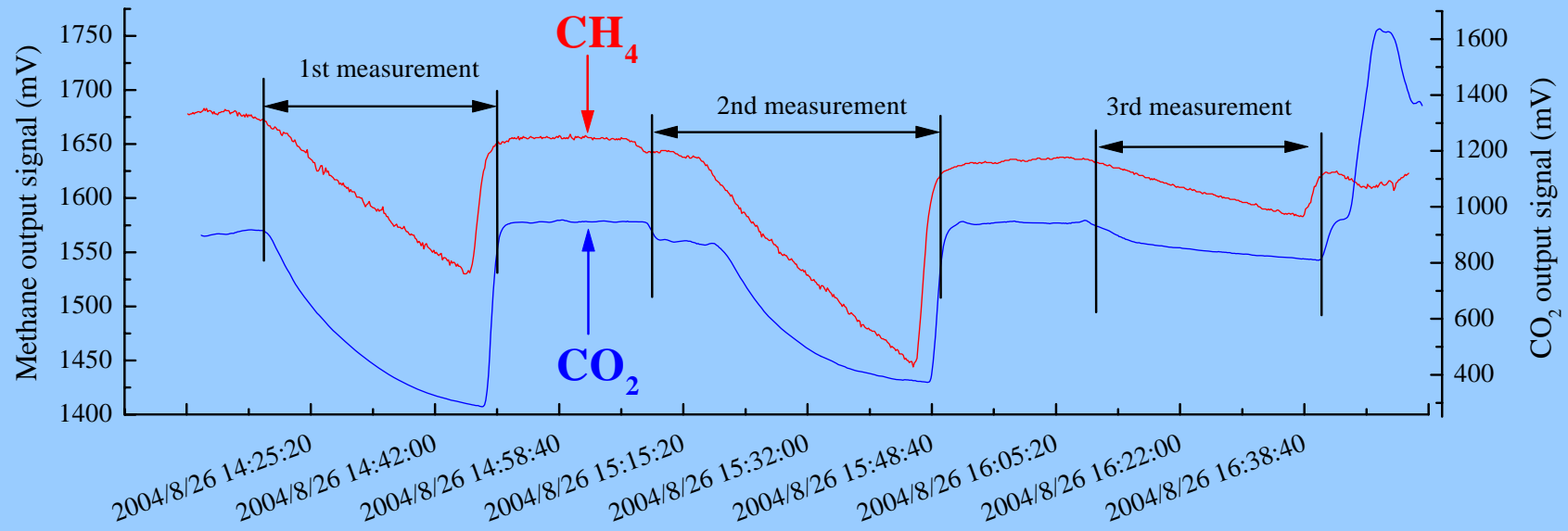

CH₄ measurements

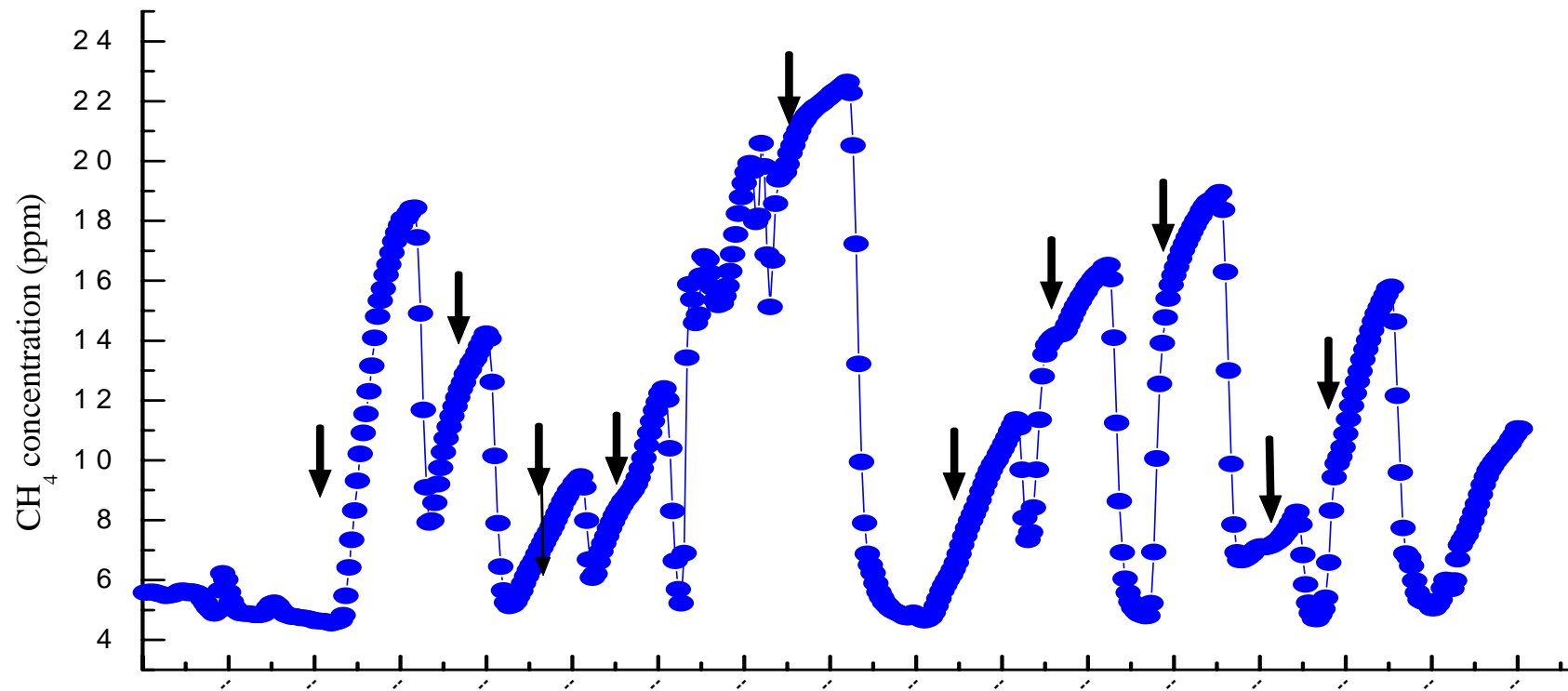

Measurement of CO₂

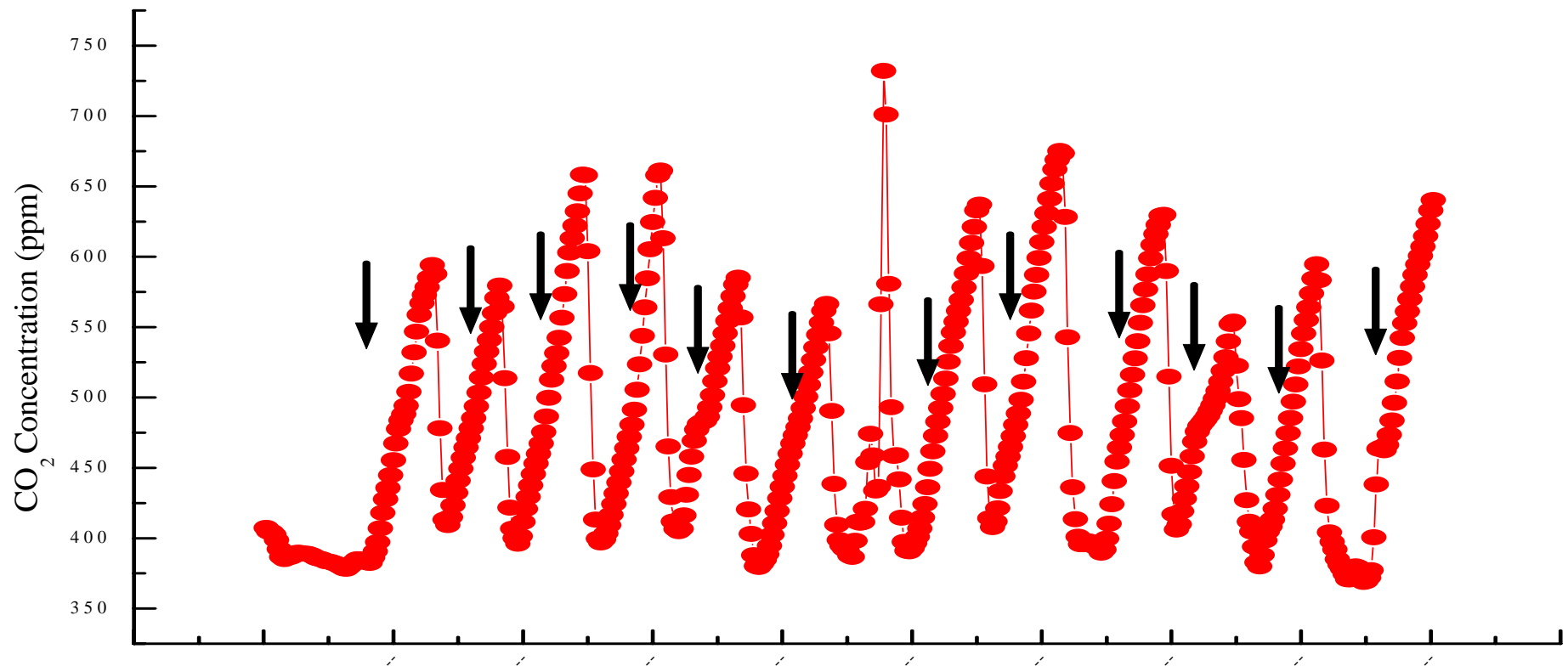

Methane Flux

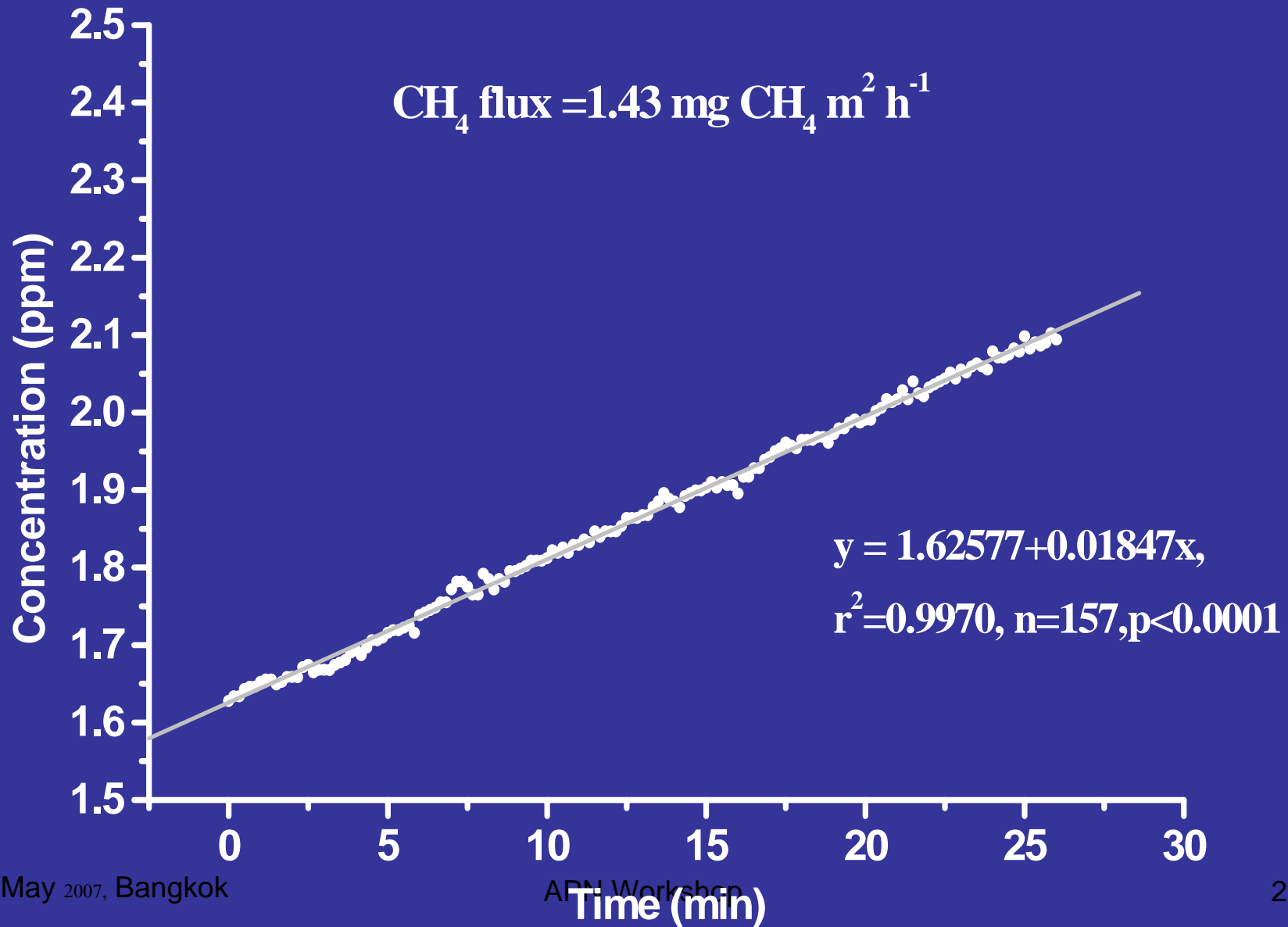

CO₂

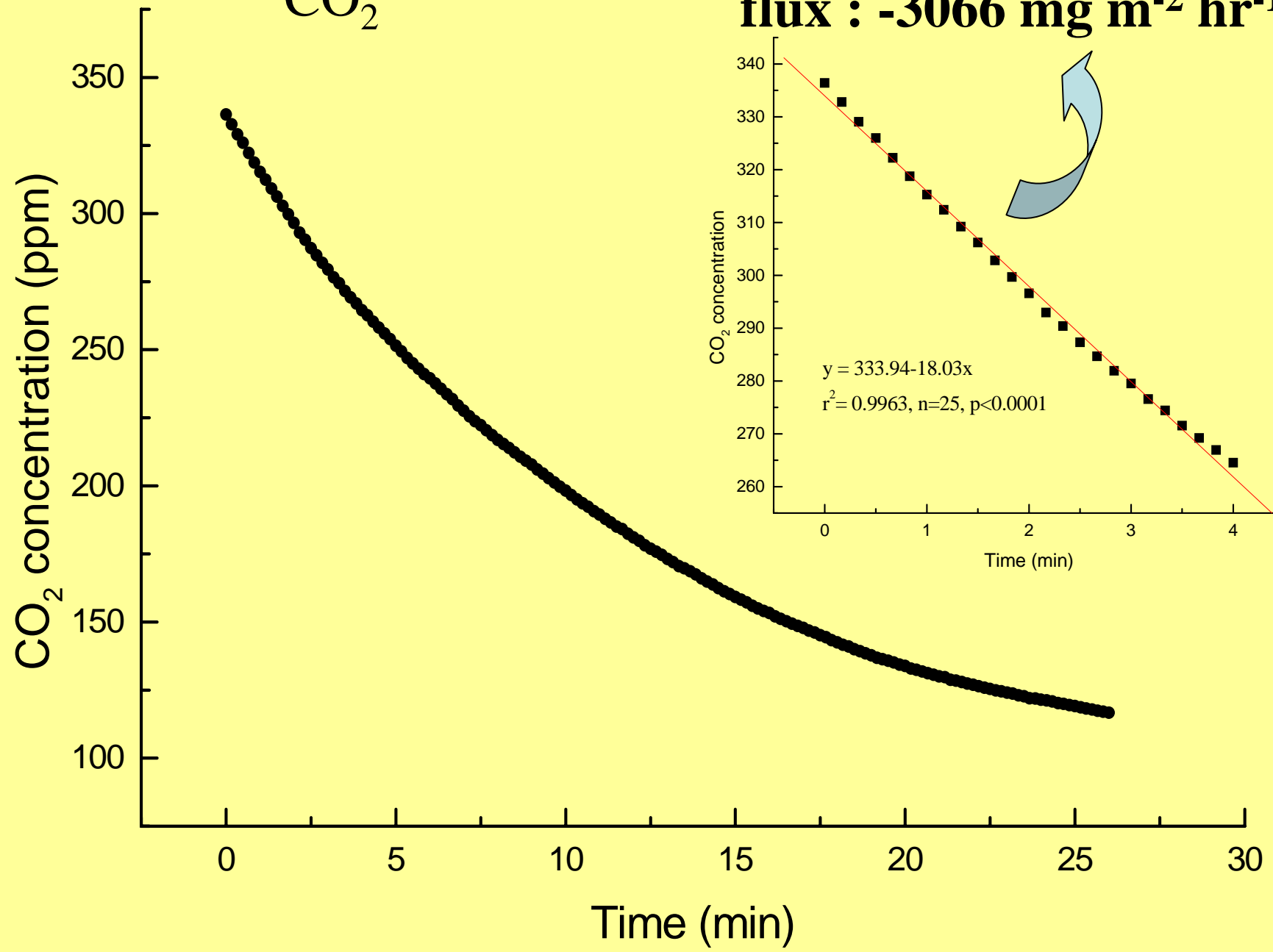

flux : -3066 mg m⁻² hr⁻¹

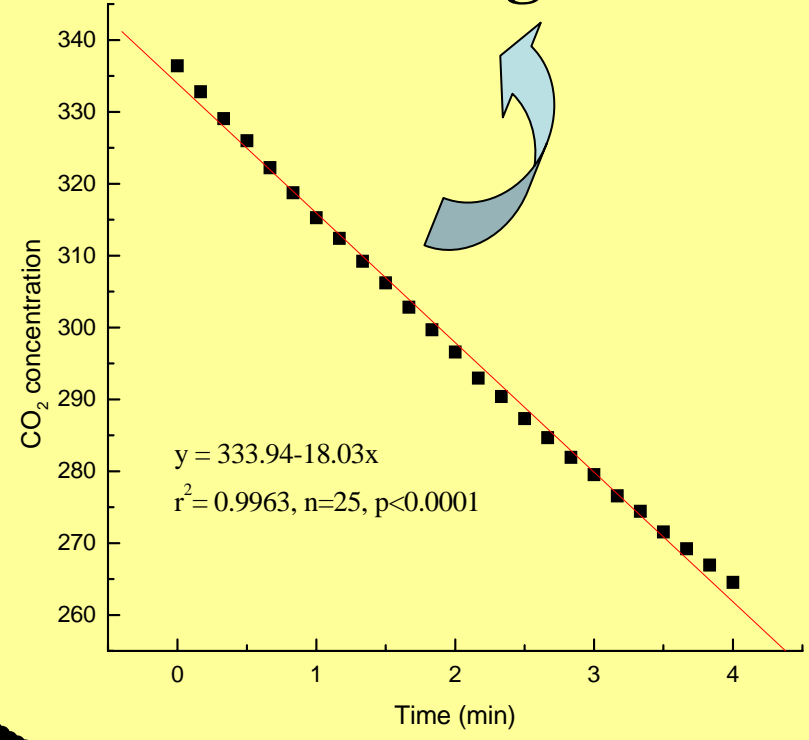

Determining CH₄ by GC

**Chamber
enclosure**

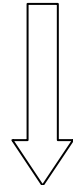

Gas samples

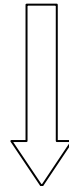

Gas Chromatography

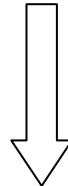

Flux estimate

